

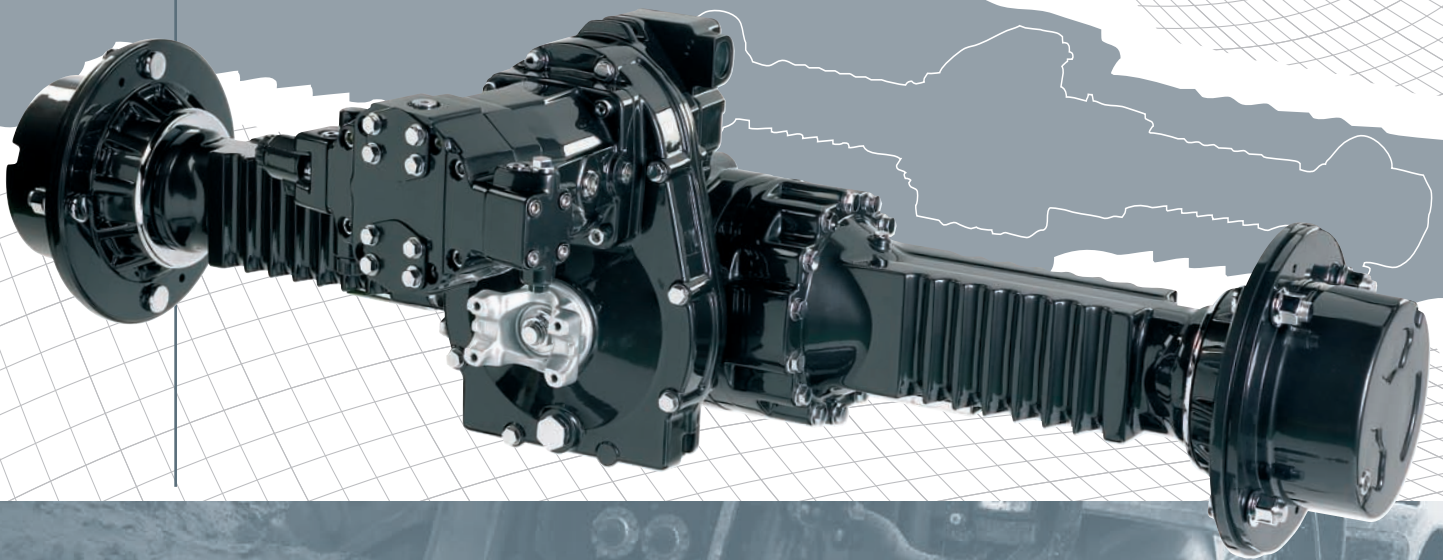

PD40 Series Axle



International Transmissions LTD
Wrexham Industrial Estate, Wrexham
North Wales, LL13 9UF, United Kingdom

Telephone: +44 (0) 1978 661140
Fax: +44 (0) 1978 664262
Email: sales@itl-trans.co.uk
www.itl-trans.com

ITL Americas Office
PO Box 957, Pooler
GA 31322, USA

Telephone: 001 912 447 2090
Fax: 001 912 447 2106
Email: roger.herauf@itl-trans.com

PD40 Series Axle



- 5,500 kg Dynamic Loading
- Pad Mount Rigid Drive Axle
- Optional Integral Transfer Box with Hydrostatic Motor Input.
- Internal Service Brakes
- Optional Internal Separate Park Brake on Hydrostatic Transfer box Input Shaft.

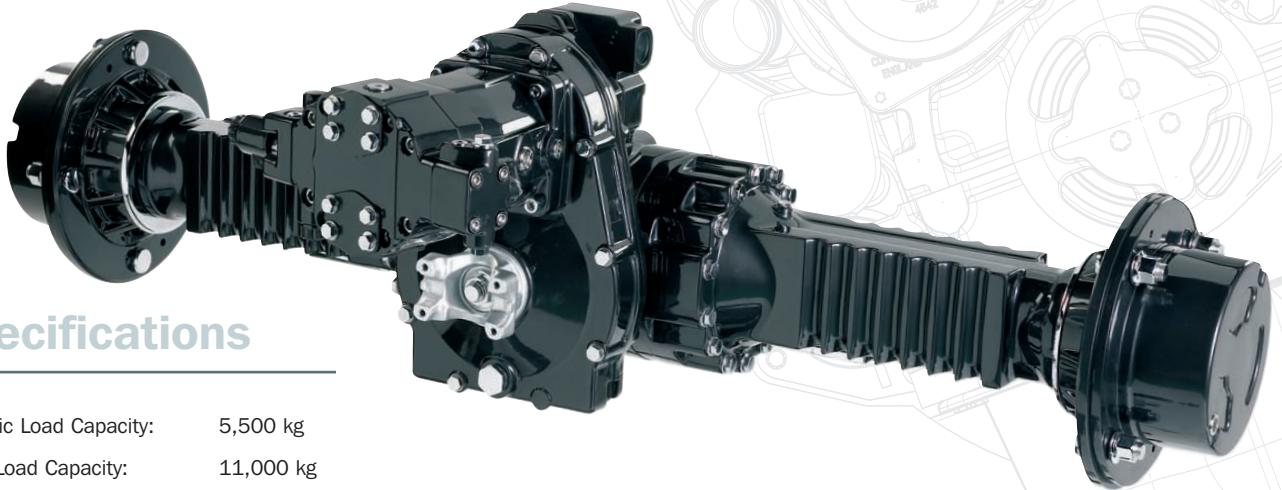

Specifications

Dynamic Load Capacity: 5,500 kg
Static Load Capacity: 11,000 kg

Maximum Continuous Torque: 7,000 Nm
Maximum Intermittent Torque: 21,000 Nm

Axle Ratio's (without dropbox): 11.65, 16.15, 19.33, 21.82
Axle Ratio (with dropbox): 19.33
Dropbox Only Ratio: 2.23

Service Brakes: Multi Plate Oil Immersed.
17,900Nm Brake Torque

Park Brake (Optional): 813Nm at Dropbox Input Shaft
Wheel Fixing: 4 or 8 Studs at 3/4" UNF on 275mm PCD

