

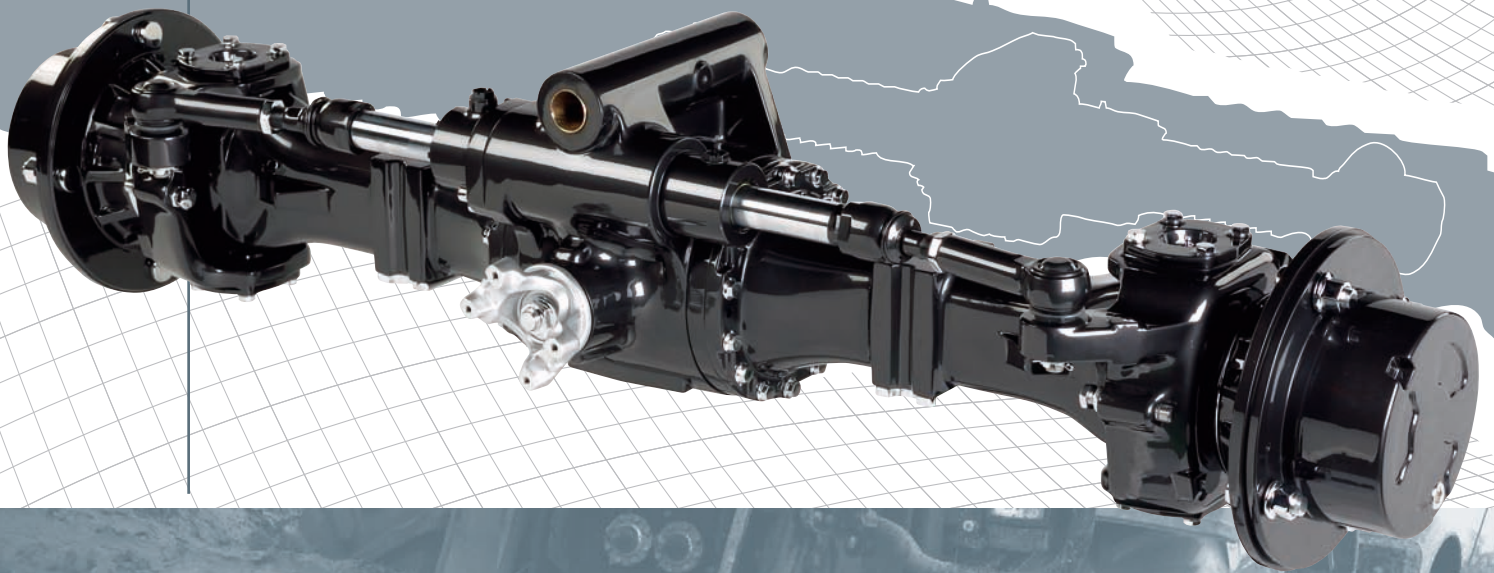

SD 40 Series Axle



International Transmissions LTD
Wrexham Industrial Estate, Wrexham
North Wales, LL13 9UF, United Kingdom

Telephone: +44 (0) 1978 661140
Fax: +44 (0) 1978 664262
Email: sales@itl-trans.co.uk
www.itl-trans.com

ITL Americas Office
PO Box 957, Pooler
GA 31322, USA

Telephone: 001 912 447 2090
Fax: 001 912 447 2106
Email: roger.herauf@itl-trans.com

SD 40 Series Axle



- **3,500 kg Dynamic Loading**
- **Pin or Pad Mount Steer Drive Axle**
- **Powered Track Rod**
- **50° Maximum Lock Angle**
- **No Service Brakes.**

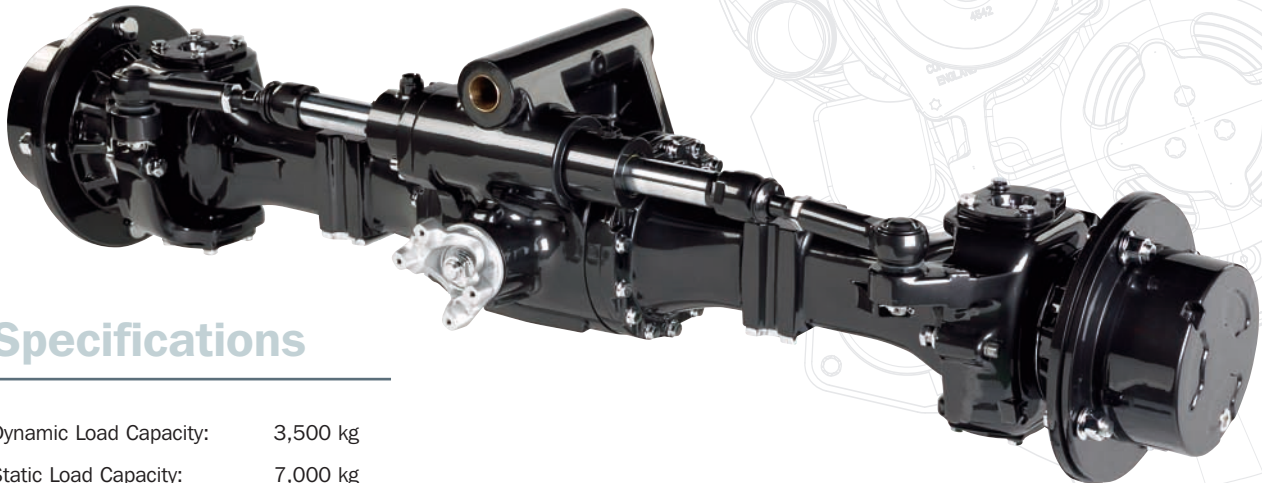

Specifications

Dynamic Load Capacity: 3,500 kg

Static Load Capacity: 7,000 kg

Maximum Continuous Torque: 7,000 Nm

Maximum Intermittent Torque: 21,000 Nm

Axle Ratio's: 11.65, 16.15, 19.33, 21.82

Steering: 50° Maximum Lock Angle
125 bar Maximum Pressure

Wheel Fixing: 4 or 8 Studs at 3/4" UNF on 275mm PCD

